



**TECHNICAL SPECIFICATIONS**

EMEA, APAC, LATAM Version



Shown: PM 722ED with optional Additional Sliding Unloading Shelf, 7-Day Automatic On/Off Timer and XTREME Performance 500°C.

Project \_\_\_\_\_

Item No. \_\_\_\_\_

Quantity \_\_\_\_\_

Date \_\_\_\_\_

# PM 72X Series

PM 721ED, PM 722ED, PM 723ED, PM 724ED, PM 725ED

## PizzaMaster® Modular Electric Deck Oven

- The world's largest range of electric deck ovens.
- Trusted in 170+ countries and counting.
- Unmatched capacity. Unstoppable output.
- Precision baking made effortless.
- Built to last. Backed for life.

International Voltage and Certifications

- Available upon request



### Standard Features

✓ IQControl Panel™	✓ Vent Control Lever for Each Deck	✓ Multi-Functional Oven Stand
✓ TempIQ Recovery™	✓ High-Density Insulation	✓ Ventilation Hood
✓ TempIQ Guard™	✓ Strong Ergonomic Oven Door Handles	✓ Disassemble Design 3/4/5-Deck Ovens Available as an option on 2-deck oven
✓ TurboStart	✓ Durable Long-Life Oven Door	✓ Resettable Overheat Protection
✓ Balanced Heat Distribution™	✓ Pull-Up Oven Door	✓ 1 & 3 Phase El. Power Supply Available
✓ 3 Heat Zones: Top, Bottom, Front	✓ Large Clear Window Glass Oven Door	✓ Flexible Power Supply for 400V Single or multiple incoming supply cables
✓ Maximum Baking Temperature: 400°C	✓ Stainless Steel Front	✓ International Voltages & Certifications Available upon request
✓ Ceramic Clay Stones w/ Crisping Function Rec. for baking temperatures up to 370°C	✓ Ventilated Front	✓ Start-Up Maintenance Kit Includes: Oven bulbs Cleaning supplies
✓ Sliding Unloading Shelf on 1/2/3-Deck Ovens 2nd shelf available as an option	✓ Bake Timer with Manual Shut-Off Alarm	
✓ Dual Xenon Oven Deck Lights	✓ Single-Push Auto Bake Timer with Alarm	
	✓ Lockable Casters on 1/2/3/4-Deck Ovens	

### Optional Features

<input type="checkbox"/> XTREME Performance™ 500°C Extended maximum baking temperature	<input type="checkbox"/> Extra High Deck N/A with XTREME Performance 500°C	<input type="checkbox"/> Side Shield Panel
<input type="checkbox"/> Artisan High-Temperature Clay Stones Rec. for baking temperatures over 370°C	<input type="checkbox"/> Power Guard™ Control system for limited power supply	<input type="checkbox"/> Additional Sliding Unloading Shelf
<input type="checkbox"/> Extended Ventilation Hood Rec. for Bakery and XTREME Performance	<input type="checkbox"/> Dual Voltage System Switchable (230V 3ph and 400V 3ph+N)	<input type="checkbox"/> Fixed Unloading Shelf on 4-Deck Oven
<input type="checkbox"/> Factory Direct Ventilation System Requires Extended Ventilation Hood	<input type="checkbox"/> Underbuilt Cabinet (UBC)	<input type="checkbox"/> Side Shelf Maximum 2 per side
<input type="checkbox"/> 7-Day Automatic On/Off Timer	<input type="checkbox"/> Underbuilt Cabinet with Proofer (UBC-P)	<input type="checkbox"/> Oil and Spice Rack Includes pizza cutter
<input type="checkbox"/> Phantom Black Finish	<input type="checkbox"/> Lockable Casters for 5-Deck Oven	<input type="checkbox"/> Pizza Tool Holder Holds up to 3 tools
<input type="checkbox"/> Disassemble Design 2-Deck Oven	<input type="checkbox"/> Marine Option Adapted for offshore installations	<input type="checkbox"/> Pizza Tools Loading Peels (33, 36, 45, 50 cm) Turning Peels (20, 23 cm) Oven Brush Freestanding Peel Holder
<input type="checkbox"/> Steam System N/A with XTREME Performance 500°C	<input type="checkbox"/> Near Coastal Option Enhanced protection against saltwater	

**One oven, multiple possibilities. Individually configured decks let you bake different products at once.**  
Example: **Deck 1** for Bakery, **Deck 2** for Standard Pizza, and **Deck 3** for High Temperature Pizza.

Technical Drawings

721  
Front  
Side  
Rear

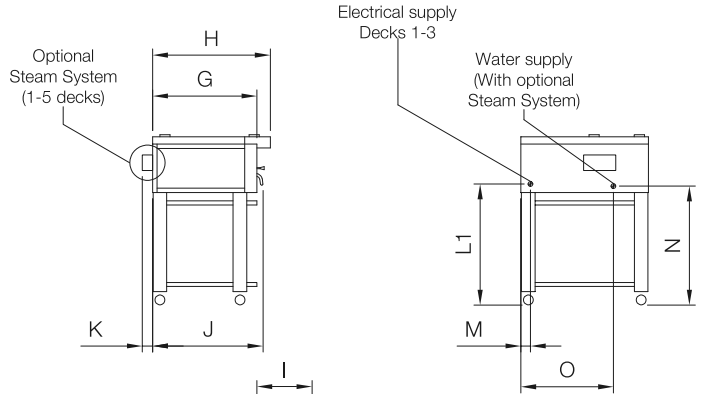
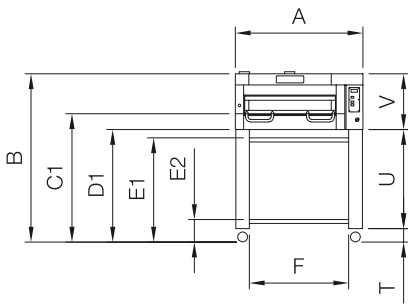

722  
Front  
Side  
Rear

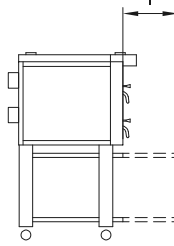
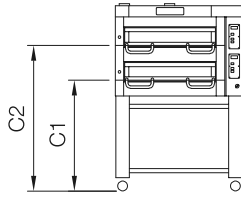

723  
Front  
Side  
Rear

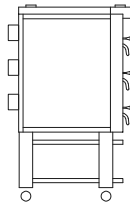
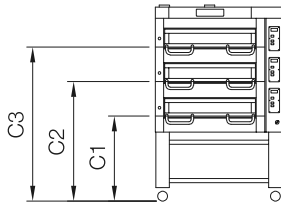

724  
Front  
Side  
Rear

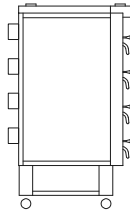
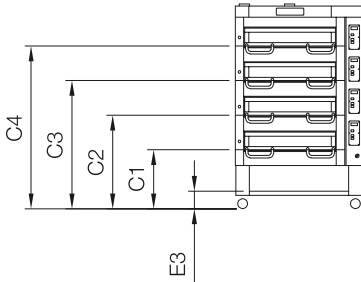

725  
Front  
Side  
Rear

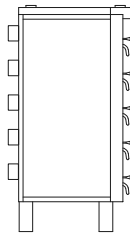
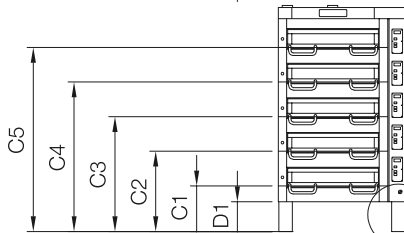

721 - 725  
Top

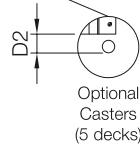
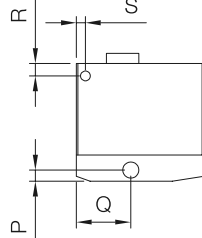

721 - 725  
Baking Surface  
Stone size

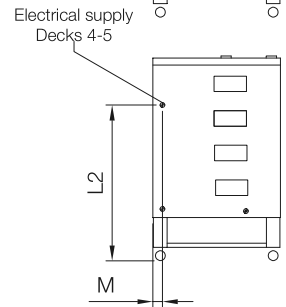
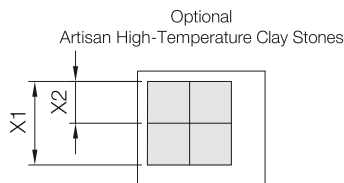
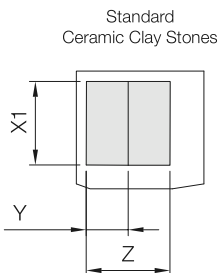

Notes

- Required 50 mm minimum clearance on all sides.
- Optional Steam System: Measurement "K" includes the required minimum clearance.
- Oven must be installed on a flat horizontal surface.
- Installation next to a deep fryer, hub, pasta cooker or similar equipment requires an optional Side Shield Panel.
- Optional Extra High Deck does not change the oven exterior height in measurement "B".

External Dimensions

See page 2	Description	Unit	721	722	723	724	725	
A	Oven Width	mm	1125	1125	1125	1125	1125	
B	Total Oven Height	a) With Hood (standard)	mm	1649	1818	1902	1987	2194
		b) Without Hood	mm	1579	1748	1832	1917	2124
C1	Height to Baking Surface, Deck 1 <sup>1)</sup>	a) Standard Deck	mm	1258	1088	833	579	447
		b) Extra High Deck (option) <sup>2)</sup>	mm	1233	1063	808	554	422
C2	Height to Baking Surface, Deck 2 <sup>1)</sup>	a) Standard Deck	mm	-	1427	1172	918	786
		b) Extra High Deck (option) <sup>2)</sup>	mm	-	1402	1147	893	761
C3	Height to Baking Surface, Deck 3 <sup>1)</sup>	a) Standard Deck	mm	-	-	1511	1257	1125
		b) Extra High Deck (option) <sup>2)</sup>	mm	-	-	1486	1232	1100
C4	Height to Baking Surface, Deck 4 <sup>1)</sup>	a) Standard Deck	mm	-	-	-	1596	1464
		b) Extra High Deck (option) <sup>2)</sup>	mm	-	-	-	1571	1439
C5	Height to Baking Surface, Deck 5 <sup>1)</sup>	a) Standard Deck	mm	-	-	-	-	1803
		b) Extra High Deck (option) <sup>2)</sup>	mm	-	-	-	-	1778
D1	Height to Bottom of Oven (standard)	mm	1102	932	677	423	291	
D2	Height to Bottom of Oven (for 5-deck ovens with optional casters) <sup>3)</sup>	mm	-	-	-	-	184	
E1	Height to Upper Sliding Shelf	mm	1021	851	596	-	-	
E2	Height to Lower Sliding Shelf	mm	212	212	212	-	-	
E3	Height to Fixed Shelf (option for 4-deck ovens)	mm	-	-	-	179	-	
F	Shelf Width	mm	978	978	978	978	978	
G	Oven Depth, with Hood	a) Ventilation Hood (standard)	mm	1038	1038	1038	1038	1038
		b) Extended Ventilation Hood (option)	mm	1208	1208	1208	1208	1208
H	Oven Depth, without Hood	mm	903	903	903	903	903	
I	Depth of Sliding Shelf when Fully Extended	mm	539	539	539	-	-	
J	Depth with Handles	a) Closed door	mm	963	963	963	963	963
		b) Open door	mm	1103	1103	1103	1103	1103
K	Depth of Steam System (option)	mm	100	100	100	100	100	
L1	Height Position for Electrical Supply, Decks 1-3 [± 25 mm]	mm	1188	1018	763	509	377	
L2	Height Position for Electrical Supply, Decks 4-5 [± 25 mm]	mm	-	-	-	1526	1394	
M	Width Position for Electrical Supply [± 50 mm]	mm	93	93	93	93	93	
N	Height Position for Water Supply (with optional Steam System)	mm	1166	996	741	487	355	
O	Width Position for Water Supply (with optional Steam System)	mm	843	843	843	843	843	
P	Depth Position for Front Ventilation (with Hood attached)	mm	110	110	110	110	110	
Q	Width Position for Front Ventilation (with Hood attached)	mm	474	474	474	474	474	
R	Depth Position for Rear Ventilation	mm	122	122	122	122	122	
S	Width Position for Rear Ventilation	mm	90	90	90	90	90	
T	Height of Casters Only (1 to 4 decks)	mm	132	132	132	132	-	
U	Height of Legs Only	mm	970	800	545	291	291	
V	Height of Oven Only	a) With Hood (standard)	mm	547	886	1225	1564	1903
		b) Without Hood	mm	477	816	1155	1494	1833

Note 1) Add +12 mm for optional Artisan High-Temperature Clay Stones.  
 Note 2) Optional Extra High Deck does not change the oven exterior height in measurement "B".  
 Note 3) All other heights are lowered by 107 mm with optional casters for 5-deck ovens.

Internal Dimensions

See page 2	Description	Unit	721	722	723	724	725	
X1	Stone size, depth - Ceramic Clay Stone (standard)	mm	710	710	710	710	710	
X2	Stone size, depth - Artisan High-Temperature Clay Stone (option)	mm	355	355	355	355	355	
Y	Stone size, width	mm	355	355	355	355	355	
-	No. of Stones	a) Ceramic Clay Stone (standard)	pcs	2	2	2	2	2
		b) Artisan HT Clay Stone (option)	pcs	4	4	4	4	4
X1	Total baking surface, depth	mm	710	710	710	710	710	
Z	Total baking surface, width	mm	710	710	710	710	710	
-	Total baking surface, area	m <sup>2</sup>	0,5	0,5	0,5	0,5	0,5	
-	Internal deck height	a) Standard Deck	mm	210	210	210	210	210
		b) Extra High Deck (option)	mm	245	245	245	245	245
-	Deck door opening height	a) Standard Deck	mm	146	146	146	146	146
		b) Extra High Deck (option)	mm	181	181	181	181	181

Packing Dimensions

Description	Unit	721	722	723	724	725
Net weight	kg	180	266	353	422	469
Gross weight (total)	kg	227	315	407	480	568
Size / Dimensions	a) Width	mm	1200	1200	1200	2000
	b) Depth	mm	1200	1200	1200	1400
	c) Height	mm	740	990	1340	1680
Volume	m <sup>3</sup>	1,07	1,43	1,93	2,42	5,94

**Guidelines for choosing the right oven**

1. Measure the available space for the oven.
2. Determine the maximum capacity need per hour and average bake time.  
(See capacity tables for guidance).
3. Note that different bake temperatures require separate decks.
4. Factor in time needed for loading and unloading pizzas.
5. Consider potential future expansion plans and the need for additional decks.



OvenIQ Configurator™

**Capacity tables**

Round pizza (mm)	Capacity, per deck	Rectangular pizza (mm)		Capacity, per deck
		Length	Width	
200	10	400	300	3
250	6	600	400	1
300	4	600	450	1
330	4	630	470	1
350	4	650	530	1
400	2	660	457	1
450	1	700	500	1
500	1	762	457	0
600	1	800	600	0

**Electrical**

Voltage	Parameters (Per deck, unless specified)		Unit	721	722	723	724	725
230 V 1 ph + N 50/60 Hz	Max. Current <sup>1)</sup>		Amps	27,5	27,7	28,0	28,2	28,4
	Average Current at normal operation		Amps	9,6	9,7	9,8	9,9	9,9
	Min. Breaker (Type C is rec.)		Amps	30,3	30,5	30,8	31,0	31,2
	Max. Power		kW	6,3	6,3	6,3	6,3	6,3
230 V 3 ph 50/60 Hz	Max. Current <sup>1)</sup>		Amps	16,0	16,2	16,4	16,6	16,8
	Average Current at normal operation		Amps	5,6	5,7	5,7	5,8	5,9
	Min. Breaker (Type C is rec.)		Amps	17,6	17,9	18,1	18,3	18,5
	Max. Power		kW	6,3	6,3	6,3	6,3	6,3
400 V 3 ph + N 50/60 Hz	Max. Current <sup>1)</sup>	a) Per deck	Amps	9,3	9,4	9,7	9,9	10,1
		b) Single cable	Amps	9,3	18,6	27,9	-	-
		c) Dual cables <sup>2)</sup>	Amps	-	-	-	27,9 + 9,3	28,1 + 18,6
	Average Current at normal operation	a) Per deck	Amps	3,3	3,3	3,4	3,5	3,5
		b) Total (oven)	Amps	3,3	6,6	10,1	13,8	17,7
	Min. Breaker (Type C is rec.)	a) Per deck	Amps	10,2	10,4	10,6	10,9	11,1
		b) Total (oven)	Amps	10,2	20,7	31,8	43,4	55,5
	Max. Power	a) Per deck	kW	6,3	6,3	6,3	6,3	6,3
		b) Total (oven)	kW	6,3	12,7	19,0	25,3	31,7

Note 1) Only at start-up (~20 min) with activated TurboStart or all heat zones at max.

Note 2) First cable for decks 1-3; Second cable for decks 4-5.

**Ventilation**

EPA 202 Tested	721	722	723	724	725
PizzaMaster electric deck ovens conform to ventilation recommendations set forth by ANSI/NFPA96 using EPA 202 test method. Grease-laden vapor test, EPA 202 (ventless requirement): 8 hr, Pepperoni pizza, < 5,00 mg/m <sup>3</sup> .	✓	✓	✓	✓	✓

How to install	Connection(s)				Air flow					
	Qty	Pos	Unit	Value	Unit	721	722	723	724	725
Factory Direct Vent. System (option) <sup>1)</sup>	1	Center	mm	200	m <sup>3</sup> /h	619	712	804	897	990
Direct Ventilation <sup>2)</sup>	2	Front	mm	160	m <sup>3</sup> /h	619	712	804	897	990
		Rear	mm	100	m <sup>3</sup> /h	15	30	44	59	74
Under External Hood	-	-	-	-	m <sup>3</sup> /h	464	534	603	673	743

Note 1) Requires Extended Ventilation Hood.

Note 2) For best performance, Extended Ventilation Hood is recommended.

Exhaust temperature (See page 3 for measurement "B/b")			
Connection	Unit	"B/b" + 400 mm	"B/b" + 1000 mm
Center <sup>1)</sup>	°C	-	42
Front <sup>2)</sup>	°C	46	42
Rear <sup>2)</sup>	°C	115	109

Note 1) With optional Factory Direct Ventilation System.

Note 2) Without optional Factory Direct Ventilation System.

Heat emission <sup>1)</sup>						
Type	Unit	721	722	723	724	725
Total	kW	2,2	4,4	6,6	8,9	11,1
Sensible	kW	0,6	1,3	1,9	2,5	3,2
Latent	kW	1,6	3,2	4,7	6,3	7,9

Note 1) At normal operation, all decks running.

**Water Only for Optional Steam System**

Requirements	Value	Requirements	Value
Water drain	Not required	Connection	G 3/4"
Backflow protection	Required, not included	General water quality	Cold Drinking Water
Auto shut-off valve	Included	Water softener	Recommended
Incoming water pressure	0,2 - 0,4 MPa	Particle filter	Recommended

Water quality requirements	Unit	Value
Magnesium (Mg)	mg/l	< 30
Calcium (Ca)	mg/l	20 - 100
Hardness	dH	4,0 - 7,0
Acidity at 20°C	pH	7,5 - 8,5
Alkalinity (HCO <sub>3</sub> )	mg/l	> 60



TECHNICAL SPECIFICATIONS

EMEA, APAC, LATAM Version



Shown: PM 732ED with optional Additional Sliding Unloading Shelf, 7-Day Automatic On/Off Timer and XTREME Performance 500°C.

Project \_\_\_\_\_

Item No. \_\_\_\_\_

Quantity \_\_\_\_\_

Date \_\_\_\_\_

# PM 73X Series

PM 731ED, PM 732ED, PM 733ED, PM 734ED, PM 735ED

## PizzaMaster® Modular Electric Deck Oven

- The world's largest range of electric deck ovens.
- Trusted in 170+ countries and counting.
- Unmatched capacity. Unstoppable output.
- Precision baking made effortless.
- Built to last. Backed for life.

International Voltage and Certifications

- Available upon request



### Standard Features

✓ IQControl Panel™	✓ Vent Control Lever for Each Deck	✓ Multi-Functional Oven Stand
✓ TempIQ Recovery™	✓ High-Density Insulation	✓ Ventilation Hood
✓ TempIQ Guard™	✓ Strong Ergonomic Oven Door Handles	✓ Disassemble Design 3/4/5-Deck Ovens Available as an option on 2-deck oven
✓ TurboStart	✓ Durable Long-Life Oven Door	✓ Resettable Overheat Protection
✓ Balanced Heat Distribution™	✓ Pull-Up Oven Door	✓ 1 & 3 Phase El. Power Supply Available
✓ 3 Heat Zones: Top, Bottom, Front	✓ Large Clear Window Glass Oven Door	✓ Flexible Power Supply for 400V Single or multiple incoming supply cables
✓ Maximum Baking Temperature: 400°C	✓ Stainless Steel Front	✓ International Voltages & Certifications Available upon request
✓ Ceramic Clay Stones w/ Crisping Function Rec. for baking temperatures up to 370°C	✓ Ventilated Front	✓ Start-Up Maintenance Kit Includes: Oven bulbs Cleaning supplies
✓ Sliding Unloading Shelf on 1/2/3-Deck Ovens 2nd shelf available as an option	✓ Bake Timer with Manual Shut-Off Alarm	
✓ Dual Xenon Oven Deck Lights	✓ Single-Push Auto Bake Timer with Alarm	
	✓ Lockable Casters on 1/2/3/4-Deck Ovens	

### Optional Features

<input type="checkbox"/> XTREME Performance™ 500°C Extended maximum baking temperature	<input type="checkbox"/> Extra High Deck N/A with XTREME Performance 500°C	<input type="checkbox"/> Side Shield Panel
<input type="checkbox"/> Artisan High-Temperature Clay Stones Rec. for baking temperatures over 370°C	<input type="checkbox"/> Power Guard™ Control system for limited power supply	<input type="checkbox"/> Additional Sliding Unloading Shelf
<input type="checkbox"/> Extended Ventilation Hood Rec. for Bakery and XTREME Performance	<input type="checkbox"/> Dual Voltage System Switchable (230V 3ph and 400V 3ph+N)	<input type="checkbox"/> Fixed Unloading Shelf on 4-Deck Oven
<input type="checkbox"/> Factory Direct Ventilation System Requires Extended Ventilation Hood	<input type="checkbox"/> Underbuilt Cabinet (UBC)	<input type="checkbox"/> Side Shelf Maximum 2 per side
<input type="checkbox"/> 7-Day Automatic On/Off Timer	<input type="checkbox"/> Underbuilt Cabinet with Proofer (UBC-P)	<input type="checkbox"/> Oil and Spice Rack Includes pizza cutter
<input type="checkbox"/> Phantom Black Finish	<input type="checkbox"/> Lockable Casters for 5-Deck Oven	<input type="checkbox"/> Pizza Tool Holder Holds up to 3 tools
<input type="checkbox"/> Disassemble Design 2-Deck Oven	<input type="checkbox"/> Marine Option Adapted for offshore installations	<input type="checkbox"/> Pizza Tools Loading Peels (33, 36, 45, 50 cm) Turning Peels (20, 23 cm) Oven Brush Freestanding Peel Holder
<input type="checkbox"/> Steam System N/A with XTREME Performance 500°C	<input type="checkbox"/> Near Coastal Option Enhanced protection against saltwater	

One oven, multiple possibilities. Individually configured decks let you bake different products at once.  
Example: Deck 1 for Bakery, Deck 2 for Standard Pizza, and Deck 3 for High Temperature Pizza.

**Technical Drawings**

**731**  
Front  
Side  
Rear

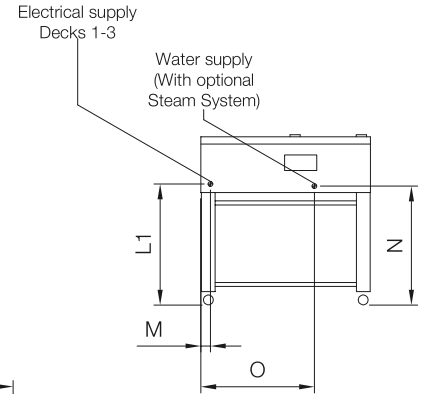
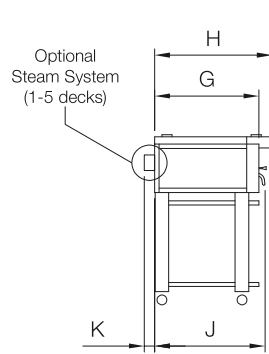
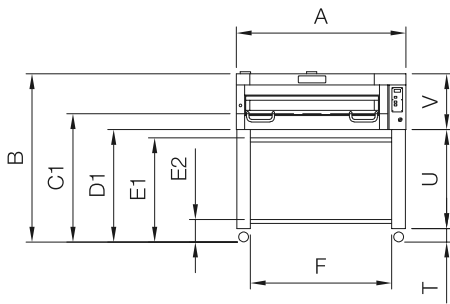

**732**  
Front  
Side  
Rear

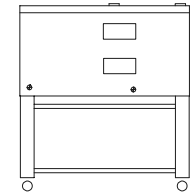
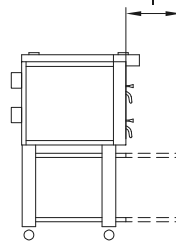
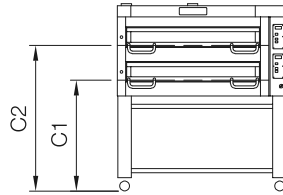

**733**  
Front  
Side  
Rear

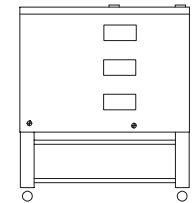
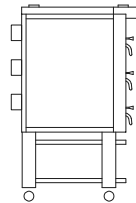
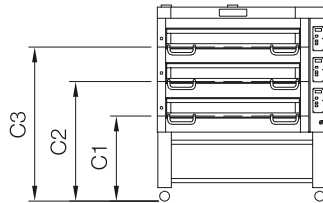

**734**  
Front  
Side  
Rear

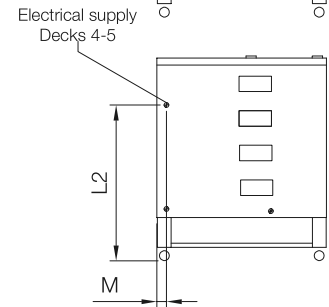
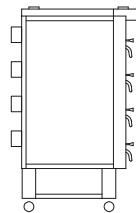
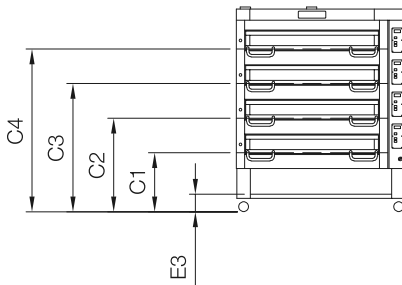

**735**  
Front  
Side  
Rear

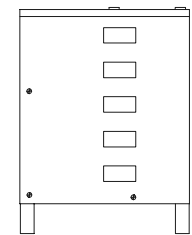
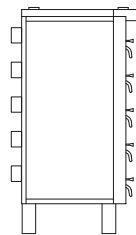
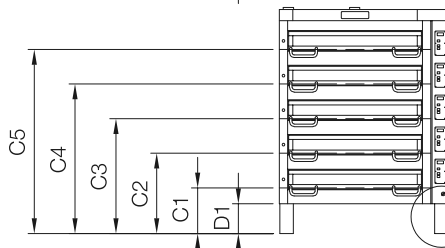

**731 - 735**  
Top

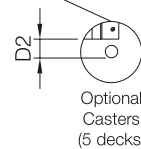
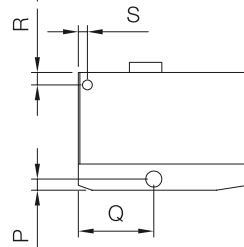

**731 - 735**  
Baking Surface  
Stone size

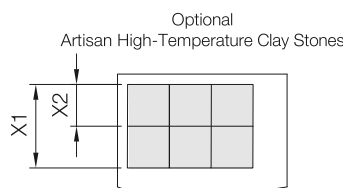
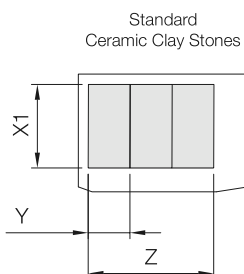

**Notes**

- Required 50 mm minimum clearance on all sides.
- Optional Steam System: Measurement "K" includes the required minimum clearance.
- Oven must be installed on a flat horizontal surface.
- Installation next to a deep fryer, hub, pasta cooker or similar equipment requires an optional Side Shield Panel.
- Optional Extra High Deck does not change the oven exterior height in measurement "B".

**External Dimensions**

See page 2	Description	Unit	731	732	733	734	735	
<b>A</b>	Oven Width	mm	1482	1482	1482	1482	1482	
<b>B</b>	Total Oven Height	a) With Hood (standard)	mm	1649	1818	1902	1987	2194
		b) Without Hood	mm	1579	1748	1832	1917	2124
<b>C1</b>	Height to Baking Surface, Deck 1 <sup>1)</sup>	a) Standard Deck	mm	1258	1088	833	579	447
		b) Extra High Deck (option) <sup>2)</sup>	mm	1233	1063	808	554	422
<b>C2</b>	Height to Baking Surface, Deck 2 <sup>1)</sup>	a) Standard Deck	mm	-	1427	1172	918	786
		b) Extra High Deck (option) <sup>2)</sup>	mm	-	1402	1147	893	761
<b>C3</b>	Height to Baking Surface, Deck 3 <sup>1)</sup>	a) Standard Deck	mm	-	-	1511	1257	1125
		b) Extra High Deck (option) <sup>2)</sup>	mm	-	-	1486	1232	1100
<b>C4</b>	Height to Baking Surface, Deck 4 <sup>1)</sup>	a) Standard Deck	mm	-	-	-	1596	1464
		b) Extra High Deck (option) <sup>2)</sup>	mm	-	-	-	1571	1439
<b>C5</b>	Height to Baking Surface, Deck 5 <sup>1)</sup>	a) Standard Deck	mm	-	-	-	-	1803
		b) Extra High Deck (option) <sup>2)</sup>	mm	-	-	-	-	1778
<b>D1</b>	Height to Bottom of Oven (standard)	mm	1102	932	677	423	291	
<b>D2</b>	Height to Bottom of Oven (for 5-deck ovens with optional casters) <sup>3)</sup>	mm	-	-	-	-	184	
<b>E1</b>	Height to Upper Sliding Shelf	mm	1021	851	596	-	-	
<b>E2</b>	Height to Lower Sliding Shelf	mm	212	212	212	-	-	
<b>E3</b>	Height to Fixed Shelf (option for 4-deck ovens)	mm	-	-	-	179	-	
<b>F</b>	Shelf Width	mm	1335	1335	1335	1335	1335	
<b>G</b>	Oven Depth, with Hood	a) Ventilation Hood (standard)	mm	1038	1038	1038	1038	1038
		b) Extended Ventilation Hood (option)	mm	1208	1208	1208	1208	1208
<b>H</b>	Oven Depth, without Hood	mm	903	903	903	903	903	
<b>I</b>	Depth of Sliding Shelf when Fully Extended	mm	539	539	539	-	-	
<b>J</b>	Depth with Handles	a) Closed door	mm	963	963	963	963	963
		b) Open door	mm	1103	1103	1103	1103	1103
<b>K</b>	Depth of Steam System (option)	mm	100	100	100	100	100	
<b>L1</b>	Height Position for Electrical Supply, Decks 1-3 [± 25 mm]	mm	1188	1018	763	509	377	
<b>L2</b>	Height Position for Electrical Supply, Decks 4-5 [± 25 mm]	mm	-	-	-	1526	1394	
<b>M</b>	Width Position for Electrical Supply [± 50 mm]	mm	93	93	93	93	93	
<b>N</b>	Height Position for Water Supply (with optional Steam System)	mm	1166	996	741	487	355	
<b>O</b>	Width Position for Water Supply (with optional Steam System)	mm	1021	1021	1021	1021	1021	
<b>P</b>	Depth Position for Front Ventilation (with Hood attached)	mm	110	110	110	110	110	
<b>Q</b>	Width Position for Front Ventilation (with Hood attached)	mm	653	653	653	653	653	
<b>R</b>	Depth Position for Rear Ventilation	mm	122	122	122	122	122	
<b>S</b>	Width Position for Rear Ventilation	mm	90	90	90	90	90	
<b>T</b>	Height of Casters Only (1 to 4 decks)	mm	132	132	132	132	-	
<b>U</b>	Height of Legs Only	mm	970	800	545	291	291	
<b>V</b>	Height of Oven Only	a) With Hood (standard)	mm	547	886	1225	1564	1903
		b) Without Hood	mm	477	816	1155	1494	1833

Note 1) Add +12 mm for optional Artisan High-Temperature Clay Stones.  
 Note 2) Optional Extra High Deck does not change the oven exterior height in measurement "B".  
 Note 3) All other heights are lowered by 107 mm with optional casters for 5-deck ovens.

**Internal Dimensions**

See page 2	Description	Unit	731	732	733	734	735	
<b>X1</b>	Stone size, depth - Ceramic Clay Stone (standard)	mm	710	710	710	710	710	
<b>X2</b>	Stone size, depth - Artisan High-Temperature Clay Stone (option)	mm	355	355	355	355	355	
<b>Y</b>	Stone size, width	mm	355	355	355	355	355	
-	No. of Stones	a) Ceramic Clay Stone (standard)	pcs	3	3	3	3	3
		b) Artisan HT Clay Stone (option)	pcs	6	6	6	6	6
<b>X1</b>	Total baking surface, depth	mm	710	710	710	710	710	
<b>Z</b>	Total baking surface, width	mm	1065	1065	1065	1065	1065	
-	Total baking surface, area	m <sup>2</sup>	0,8	0,8	0,8	0,8	0,8	
-	Internal deck height	a) Standard Deck	mm	210	210	210	210	210
		b) Extra High Deck (option)	mm	245	245	245	245	245
-	Deck door opening height	a) Standard Deck	mm	146	146	146	146	146
		b) Extra High Deck (option)	mm	181	181	181	181	181

**Packing Dimensions**

Description	Unit	731	732	733	734	735	
Net weight	kg	227	325	450	495	572	
Gross weight (total)	kg	290	390	520	569	671	
Size / Dimensions	a) Width	mm	1600	1600	1600	1600	2000
	b) Depth	mm	1200	1200	1200	1200	1400
	c) Height	mm	740	990	1340	1680	2120
Volume	m <sup>3</sup>	1,42	1,90	2,57	3,23	5,94	

### Guidelines for choosing the right oven

1. Measure the available space for the oven.
2. Determine the maximum capacity need per hour and average bake time.  
(See capacity tables for guidance).
3. Note that different bake temperatures require separate decks.
4. Factor in time needed for loading and unloading pizzas.
5. Consider potential future expansion plans and the need for additional decks.



OvenIQ  
Configurator™

### Capacity tables

Round pizza (mm)	Capacity, per deck	Rectangular pizza (mm)		Capacity, per deck
		Length	Width	
200	16	400	300	4
250	11	600	400	2
300	7	600	450	2
330	6	630	470	2
350	6	650	530	2
400	3	660	457	2
450	2	700	500	2
500	2	762	457	1
600	1	800	600	1

### Electrical

Voltage	Parameters (Per deck, unless specified)		Unit	731	732	733	734	735
230 V 1 ph + N 50/60 Hz	Max. Current <sup>1)</sup>		Amps	41,1	41,3	41,5	41,7	42,0
	Average Current at normal operation		Amps	14,4	14,5	14,5	14,6	14,7
	Min. Breaker (Type C is rec.)		Amps	45,2	45,4	45,7	45,9	46,2
	Max. Power		kW	9,5	9,5	9,5	9,5	9,5
230 V 3 ph 50/60 Hz	Max. Current <sup>1)</sup>		Amps	23,9	24,1	24,3	24,5	24,7
	Average Current at normal operation		Amps	8,4	8,4	8,5	8,6	8,6
	Min. Breaker (Type C is rec.)		Amps	26,3	26,5	26,7	26,9	27,1
	Max. Power		kW	9,5	9,5	9,5	9,5	9,5
400 V 3 ph + N 50/60 Hz	Max. Current <sup>1)</sup>	a) Per deck	Amps	13,9	13,9	14,1	14,4	14,6
		b) Single cable	Amps	13,9	27,8	41,7	-	-
		c) Dual cables <sup>2)</sup>	Amps	-	-	-	41,7 + 13,9	41,7 + 27,8
	Average Current at normal operation	a) Per deck	Amps	4,9	4,9	4,9	5,0	5,1
		b) Total (oven)	Amps	4,9	9,7	14,8	20,1	25,5
	Min. Breaker (Type C is rec.)	a) Per deck	Amps	15,3	15,3	15,5	15,8	16,0
		b) Total (oven)	Amps	15,3	30,6	46,6	63,1	80,1
	Max. Power	a) Per deck	kW	9,5	9,5	9,5	9,5	9,5
b) Total (oven)		kW	9,5	18,9	28,4	37,8	47,3	

Note 1) Only at start-up (~20 min) with activated TurboStart or all heat zones at max.

Note 2) First cable for decks 1-3; Second cable for decks 4-5.

### Ventilation

EPA 202 Tested	731	732	733	734	735
PizzaMaster electric deck ovens conform to ventilation recommendations set forth by ANSI/NFPA96 using EPA 202 test method. Grease-laden vapor test, EPA 202 (ventless requirement): 8 hr, Pepperoni pizza, < 5,00 mg/m <sup>3</sup> .	✓	✓	✓	✓	✓

How to install	Connection(s)				Air flow					
	Qty	Pos	Unit	Value	Unit	731	732	733	734	735
Factory Direct Vent. System (option) <sup>1)</sup>	1	Center	mm	200	m <sup>3</sup> /h	814	936	1058	1180	1302
Direct Ventilation <sup>2)</sup>	2	Front	mm	160	m <sup>3</sup> /h	814	936	1058	1180	1302
		Rear	mm	100	m <sup>3</sup> /h	22	44	67	89	111
Under External Hood	-	-	-	-	m <sup>3</sup> /h	611	702	794	885	977

Note 1) Requires Extended Ventilation Hood.

Note 2) For best performance, Extended Ventilation Hood is recommended.

Exhaust temperature (See page 3 for measurement "B/b")			
Connection	Unit	"B/b" + 400 mm	"B/b" + 1000 mm
Center <sup>1)</sup>	°C	-	42
Front <sup>2)</sup>	°C	46	42
Rear <sup>2)</sup>	°C	115	109

Note 1) With optional Factory Direct Ventilation System.

Note 2) Without optional Factory Direct Ventilation System.

Heat emission <sup>1)</sup>						
Type	Unit	731	732	733	734	735
Total	kW	3,3	6,6	9,9	13,2	16,5
Sensible	kW	0,9	1,9	2,8	3,8	4,7
Latent	kW	2,4	4,7	7,1	9,5	11,8

Note 1) At normal operation, all decks running.

### Water Only for Optional Steam System

Requirements	Value	Requirements	Value
Water drain	Not required	Connection	G 3/4"
Backflow protection	Required, not included	General water quality	Cold Drinking Water
Auto shut-off valve	Included	Water softener	Recommended
Incoming water pressure	0,2 - 0,4 MPa	Particle filter	Recommended

Water quality requirements	Unit	Value
Magnesium (Mg)	mg/l	< 30
Calcium (Ca)	mg/l	20 - 100
Hardness	dH	4,0 - 7,0
Acidity at 20°C	pH	7,5 - 8,5
Alkalinity (HCO <sub>3</sub> )	mg/l	> 60



TECHNICAL SPECIFICATIONS

EMEA, APAC, LATAM Version

Project \_\_\_\_\_  
 Item No. \_\_\_\_\_  
 Quantity \_\_\_\_\_  
 Date \_\_\_\_\_



Shown: PM 742ED with optional Additional Sliding Unloading Shelf, 7-Day Automatic On/Off Timer and XTREME Performance 500°C.

# PM 74X Series

PM 741ED, PM 742ED, PM 743ED, PM 744ED, PM 745ED

## PizzaMaster® Modular Electric Deck Oven

- The world's largest range of electric deck ovens.
- Trusted in 170+ countries and counting.
- Unmatched capacity. Unstoppable output.
- Precision baking made effortless.
- Built to last. Backed for life.

International Voltage and Certifications

- Available upon request



### Standard Features

✓ IQControl Panel™	✓ Vent Control Lever for Each Deck	✓ Multi-Functional Oven Stand
✓ TempIQ Recovery™	✓ High-Density Insulation	✓ Ventilation Hood
✓ TempIQ Guard™	✓ Strong Ergonomic Oven Door Handles	✓ Disassemble Design 3/4/5-Deck Ovens Available as an option on 2-deck oven
✓ TurboStart	✓ Durable Long-Life Oven Door	✓ Resettable Overheat Protection
✓ Balanced Heat Distribution™	✓ Pull-Up Oven Door	✓ 1 & 3 Phase El. Power Supply Available
✓ 3 Heat Zones: Top, Bottom, Front	✓ Large Clear Window Glass Oven Door	✓ Flexible Power Supply for 400V Single or multiple incoming supply cables
✓ Maximum Baking Temperature: 400°C	✓ Stainless Steel Front	✓ International Voltages & Certifications Available upon request
✓ Ceramic Clay Stones w/ Crisping Function Rec. for baking temperatures up to 370°C	✓ Ventilated Front	✓ Start-Up Maintenance Kit Includes: Oven bulbs Cleaning supplies
✓ Sliding Unloading Shelf on 1/2/3-Deck Ovens 2nd shelf available as an option	✓ Bake Timer with Manual Shut-Off Alarm	
✓ Dual Xenon Oven Deck Lights	✓ Single-Push Auto Bake Timer with Alarm	
	✓ Lockable Casters on 1/2/3/4-Deck Ovens	

### Optional Features

<input type="checkbox"/> XTREME Performance™ 500°C Extended maximum baking temperature	<input type="checkbox"/> Extra High Deck N/A with XTREME Performance 500°C	<input type="checkbox"/> Side Shield Panel
<input type="checkbox"/> Artisan High-Temperature Clay Stones Rec. for baking temperatures over 370°C	<input type="checkbox"/> Power Guard™ Control system for limited power supply	<input type="checkbox"/> Additional Sliding Unloading Shelf
<input type="checkbox"/> Extended Ventilation Hood Rec. for Bakery and XTREME Performance	<input type="checkbox"/> Dual Voltage System Switchable (230V 3ph and 400V 3ph+N)	<input type="checkbox"/> Fixed Unloading Shelf on 4-Deck Oven
<input type="checkbox"/> Factory Direct Ventilation System Requires Extended Ventilation Hood	<input type="checkbox"/> Underbuilt Cabinet (UBC)	<input type="checkbox"/> Side Shelf Maximum 2 per side
<input type="checkbox"/> 7-Day Automatic On/Off Timer	<input type="checkbox"/> Underbuilt Cabinet with Proofer (UBC-P)	<input type="checkbox"/> Oil and Spice Rack Includes pizza cutter
<input type="checkbox"/> Phantom Black Finish	<input type="checkbox"/> Lockable Casters for 5-Deck Oven	<input type="checkbox"/> Pizza Tool Holder Holds up to 3 tools
<input type="checkbox"/> Disassemble Design 2-Deck Oven	<input type="checkbox"/> Marine Option Adapted for offshore installations	<input type="checkbox"/> Pizza Tools Loading Peels (33, 36, 45, 50 cm) Turning Peels (20, 23 cm) Oven Brush Freestanding Peel Holder
<input type="checkbox"/> Steam System N/A with XTREME Performance 500°C	<input type="checkbox"/> Near Coastal Option Enhanced protection against saltwater	

One oven, multiple possibilities. Individually configured decks let you bake different products at once.  
 Example: Deck 1 for Bakery, Deck 2 for Standard Pizza, and Deck 3 for High Temperature Pizza.

Technical Drawings

741  
Front  
Side  
Rear

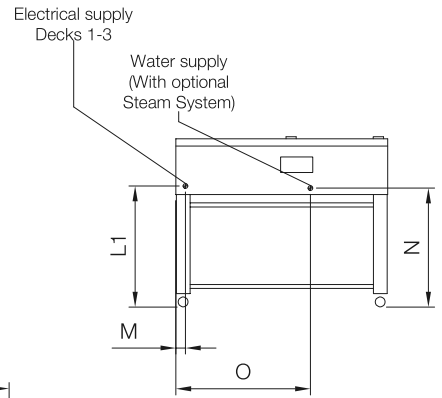
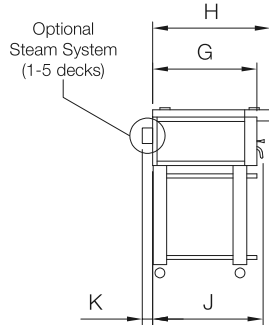
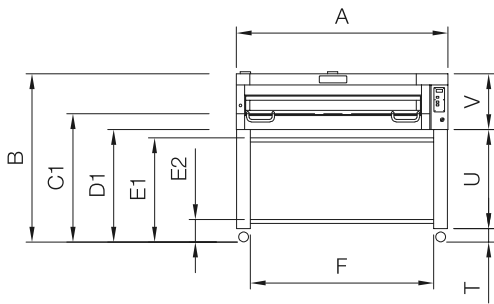

742  
Front  
Side  
Rear

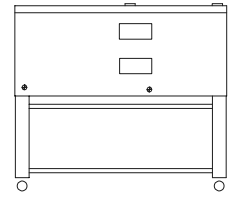
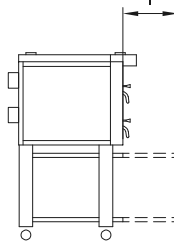
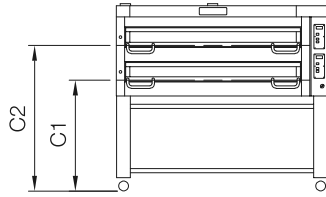

743  
Front  
Side  
Rear

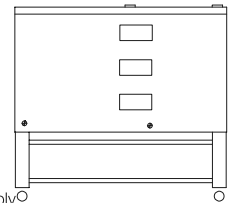
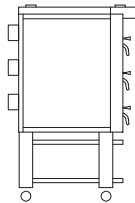
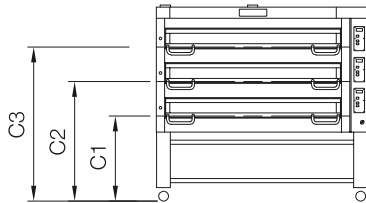

744  
Front  
Side  
Rear

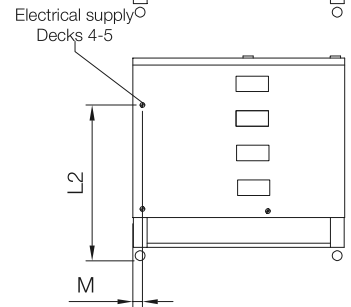
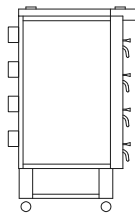
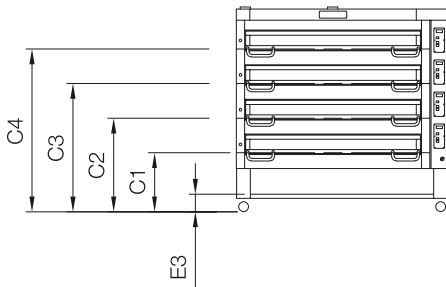

745  
Front  
Side  
Rear

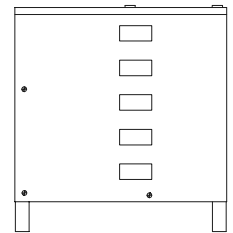
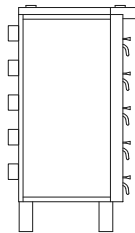
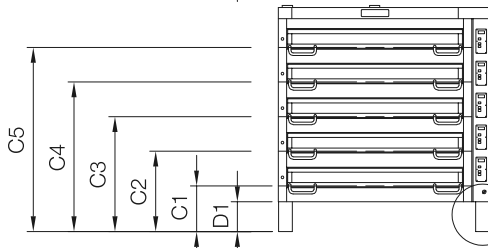

741 - 745  
Top

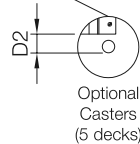
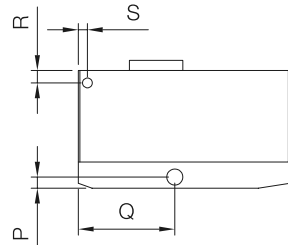

741 - 745  
Baking Surface  
Stone size

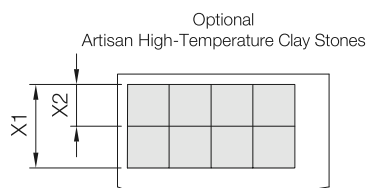
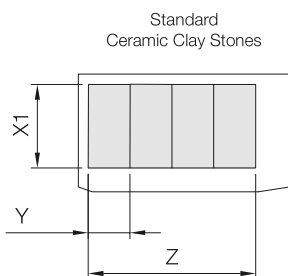

Notes

- Required 50 mm minimum clearance on all sides.
- Optional Steam System: Measurement "K" includes the required minimum clearance.
- Oven must be installed on a flat horizontal surface.
- Installation next to a deep fryer, hub, pasta cooker or similar equipment requires an optional Side Shield Panel.
- Optional Extra High Deck does not change the oven exterior height in measurement "B".

External Dimensions

See page 2	Description	Unit	741	742	743	744	745	
A	Oven Width	mm	1839	1839	1839	1839	1839	
B	Total Oven Height	a) With Hood (standard)	mm	1649	1818	1902	1987	2194
		b) Without Hood	mm	1579	1748	1832	1917	2124
C1	Height to Baking Surface, Deck 1 <sup>1)</sup>	a) Standard Deck	mm	1258	1088	833	579	447
		b) Extra High Deck (option) <sup>2)</sup>	mm	1233	1063	808	554	422
C2	Height to Baking Surface, Deck 2 <sup>1)</sup>	a) Standard Deck	mm	-	1427	1172	918	786
		b) Extra High Deck (option) <sup>2)</sup>	mm	-	1402	1147	893	761
C3	Height to Baking Surface, Deck 3 <sup>1)</sup>	a) Standard Deck	mm	-	-	1511	1257	1125
		b) Extra High Deck (option) <sup>2)</sup>	mm	-	-	1486	1232	1100
C4	Height to Baking Surface, Deck 4 <sup>1)</sup>	a) Standard Deck	mm	-	-	-	1596	1464
		b) Extra High Deck (option) <sup>2)</sup>	mm	-	-	-	1571	1439
C5	Height to Baking Surface, Deck 5 <sup>1)</sup>	a) Standard Deck	mm	-	-	-	-	1803
		b) Extra High Deck (option) <sup>2)</sup>	mm	-	-	-	-	1778
D1	Height to Bottom of Oven (standard)	mm	1102	932	677	423	291	
D2	Height to Bottom of Oven (for 5-deck ovens with optional casters) <sup>3)</sup>	mm	-	-	-	-	184	
E1	Height to Upper Sliding Shelf	mm	1021	851	596	-	-	
E2	Height to Lower Sliding Shelf	mm	212	212	212	-	-	
E3	Height to Fixed Shelf (option for 4-deck ovens)	mm	-	-	-	179	-	
F	Shelf Width	mm	1692	1692	1692	1692	1692	
G	Oven Depth, with Hood	a) Ventilation Hood (standard)	mm	1038	1038	1038	1038	1038
		b) Extended Ventilation Hood (option)	mm	1208	1208	1208	1208	1208
H	Oven Depth, without Hood	mm	903	903	903	903	903	
I	Depth of Sliding Shelf when Fully Extended	mm	539	539	539	-	-	
J	Depth with Handles	a) Closed door	mm	963	963	963	963	963
		b) Open door	mm	1103	1103	1103	1103	1103
K	Depth of Steam System (option)	mm	100	100	100	100	100	
L1	Height Position for Electrical Supply, Decks 1-3 [± 25 mm]	mm	1188	1018	763	509	377	
L2	Height Position for Electrical Supply, Decks 4-5 [± 25 mm]	mm	-	-	-	1526	1394	
M	Width Position for Electrical Supply [± 50 mm]	mm	93	93	93	93	93	
N	Height Position for Water Supply (with optional Steam System)	mm	1166	996	741	487	355	
O	Width Position for Water Supply (with optional Steam System)	mm	1200	1200	1200	1200	1200	
P	Depth Position for Front Ventilation (with Hood attached)	mm	110	110	110	110	110	
Q	Width Position for Front Ventilation (with Hood attached)	mm	831	831	831	831	831	
R	Depth Position for Rear Ventilation	mm	122	122	122	122	122	
S	Width Position for Rear Ventilation	mm	90	90	90	90	90	
T	Height of Casters Only (1 to 4 decks)	mm	132	132	132	132	-	
U	Height of Legs Only	mm	970	800	545	291	291	
V	Height of Oven Only	a) With Hood (standard)	mm	547	886	1225	1564	1903
		b) Without Hood	mm	477	816	1155	1494	1833

Note 1) Add +12 mm for optional Artisan High-Temperature Clay Stones.  
 Note 2) Optional Extra High Deck does not change the oven exterior height in measurement "B".  
 Note 3) All other heights are lowered by 107 mm with optional casters for 5-deck ovens.

Internal Dimensions

See page 2	Description	Unit	741	742	743	744	745	
X1	Stone size, depth - Ceramic Clay Stone (standard)	mm	710	710	710	710	710	
X2	Stone size, depth - Artisan High-Temperature Clay Stone (option)	mm	355	355	355	355	355	
Y	Stone size, width	mm	355	355	355	355	355	
-	No. of Stones	a) Ceramic Clay Stone (standard)	pcs	4	4	4	4	4
		b) Artisan HT Clay Stone (option)	pcs	8	8	8	8	8
X1	Total baking surface, depth	mm	710	710	710	710	710	
Z	Total baking surface, width	mm	1420	1420	1420	1420	1420	
-	Total baking surface, area	m <sup>2</sup>	1,0	1,0	1,0	1,0	1,0	
-	Internal deck height	a) Standard Deck	mm	210	210	210	210	210
		b) Extra High Deck (option)	mm	245	245	245	245	245
-	Deck door opening height	a) Standard Deck	mm	146	146	146	146	146
		b) Extra High Deck (option)	mm	181	181	181	181	181

Packing Dimensions

Description	Unit	741	742	743	744	745
Net weight	kg	256	408	528	642	770
Gross weight (total)	kg	330	485	610	728	867
Size / Dimensions	a) Width	mm	2000	2000	2000	2000
	b) Depth	mm	1200	1200	1200	1400
	c) Height	mm	740	990	1340	1680
Volume	m <sup>3</sup>	1,78	2,38	3,22	4,03	5,94

### Guidelines for choosing the right oven

1. Measure the available space for the oven.
2. Determine the maximum capacity need per hour and average bake time.  
(See capacity tables for guidance).
3. Note that different bake temperatures require separate decks.
4. Factor in time needed for loading and unloading pizzas.
5. Consider potential future expansion plans and the need for additional decks.



OvenIQ  
Configurator™

### Capacity tables

Round pizza (mm)	Capacity, per deck	Rectangular pizza (mm)		Capacity, per deck
		Length	Width	
200	21	400	300	7
250	15	600	400	3
300	9	600	450	3
330	8	630	470	3
350	8	650	530	2
400	5	660	457	3
450	3	700	500	2
500	3	762	457	1
600	2	800	600	1

### Electrical

Voltage	Parameters (Per deck, unless specified)	Unit	741	742	743	744	745	
230 V 1 ph + N 50/60 Hz	Max. Current <sup>1)</sup>	Amps	54,7	54,9	55,1	55,3	55,5	
	Average Current at normal operation	Amps	19,1	19,2	19,3	19,4	19,4	
	Min. Breaker (Type C is rec.)	Amps	60,1	60,4	60,6	60,8	61,1	
	Max. Power	kW	12,6	12,6	12,6	12,6	12,6	
230 V 3 ph 50/60 Hz	Max. Current <sup>1)</sup>	Amps	31,8	32,0	32,2	32,3	32,5	
	Average Current at normal operation	Amps	11,1	11,2	11,3	11,3	11,4	
	Min. Breaker (Type C is rec.)	Amps	35,0	35,2	35,4	35,6	35,8	
	Max. Power	kW	12,6	12,6	12,6	12,6	12,6	
400 V 3 ph + N 50/60 Hz	Max. Current <sup>1)</sup>	a) Per deck	Amps	18,5	18,5	18,6	18,8	19,0
		b) Single cable	Amps	18,5	37,0	55,6	-	-
		c) Dual cables <sup>2)</sup>	Amps	-	-	-	55,6 + 18,5	55,6 + 37,0
	Average Current at normal operation	a) Per deck	Amps	6,5	6,5	6,5	6,6	6,7
		b) Total (oven)	Amps	6,5	13,0	19,5	26,4	33,3
	Min. Breaker (Type C is rec.)	a) Per deck	Amps	20,4	20,4	20,5	20,7	20,9
		b) Total (oven)	Amps	20,4	40,7	61,4	82,9	104,7
	Max. Power	a) Per deck	kW	12,6	12,6	12,6	12,6	12,6
b) Total (oven)		kW	12,6	25,1	37,7	50,3	62,9	

Note 1) Only at start-up (~20 min) with activated TurboStart or all heat zones at max.

Note 2) First cable for decks 1-3; Second cable for decks 4-5.

### Ventilation

EPA 202 Tested	741	742	743	744	745
PizzaMaster electric deck ovens conform to ventilation recommendations set forth by ANSI/NFPA96 using EPA 202 test method. Grease-laden vapor test, EPA 202 (ventless requirement): 8 hr, Pepperoni pizza, < 5,00 mg/m <sup>3</sup> .	✓	✓	✓	✓	✓

How to install	Connection(s)				Air flow					
	Qty	Pos	Unit	Value	Unit	741	742	743	744	745
Factory Direct Vent. System (option) <sup>1)</sup>	1	Center	mm	200	m <sup>3</sup> /h	1009	1161	1312	1463	1615
Direct Ventilation <sup>2)</sup>	2	Front	mm	160	m <sup>3</sup> /h	1009	1161	1312	1463	1615
		Rear	mm	100	m <sup>3</sup> /h	30	59	89	119	148
Under External Hood	-	-	-	-	m <sup>3</sup> /h	757	870	984	1098	1211

Note 1) Requires Extended Ventilation Hood.

Note 2) For best performance, Extended Ventilation Hood is recommended.

Exhaust temperature (See page 3 for measurement "B/b")			
Connection	Unit	"B/b" + 400 mm	"B/b" + 1000 mm
Center <sup>1)</sup>	°C	-	42
Front <sup>2)</sup>	°C	46	42
Rear <sup>2)</sup>	°C	115	109

Note 1) With optional Factory Direct Ventilation System.

Note 2) Without optional Factory Direct Ventilation System.

Heat emission <sup>1)</sup>						
Type	Unit	741	742	743	744	745
Total	kW	4,4	8,8	13,2	17,6	22,0
Sensible	kW	1,3	2,5	3,8	5,0	6,3
Latent	kW	3,1	6,3	9,4	12,6	15,7

Note 1) At normal operation, all decks running.

### Water Only for Optional Steam System

Requirements	Value	Requirements	Value
Water drain	Not required	Connection	G 3/4"
Backflow protection	Required, not included	General water quality	Cold Drinking Water
Auto shut-off valve	Included	Water softener	Recommended
Incoming water pressure	0,2 - 0,4 MPa	Particle filter	Recommended

Water quality requirements	Unit	Value
Magnesium (Mg)	mg/l	< 30
Calcium (Ca)	mg/l	20 - 100
Hardness	dH	4,0 - 7,0
Acidity at 20°C	pH	7,5 - 8,5
Alkalinity (HCO <sub>3</sub> )	mg/l	> 60